



# RIDEA Seatpost Clamp for Brompton Installation Instructions

Tel.: +886 04 771 5639  
Fax: +886 04 772 0539

[www.rideabikes.com](http://www.rideabikes.com)  
[service@rideabikes.com](mailto:service@rideabikes.com)



## Product parts

**A** QR lever & axle

**B** Frame release



**C** Fixing nut & washer

**D** Sleeve

**E** Spring

**F** Ti sleeve

**G** T line original spring

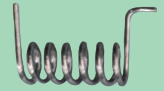
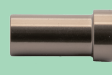
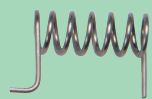
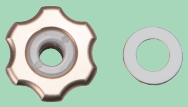

**C P**

C Line and P Line, the parts should follow this sequence:

**A** ▶ **D** ▶ **B** ▶ **E** ▶ **C**

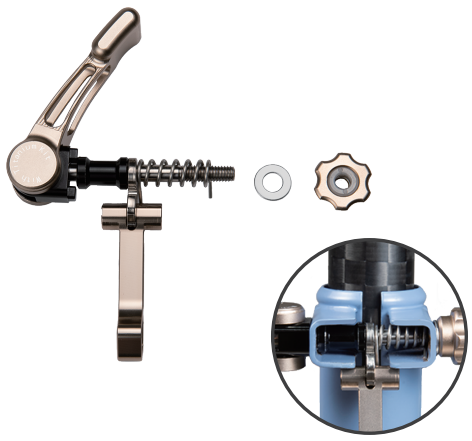

**T**

T Line the different parts should follow this sequence:

**A** ▶ **G** ▶ **B** ▶ **F** ▶ **C**

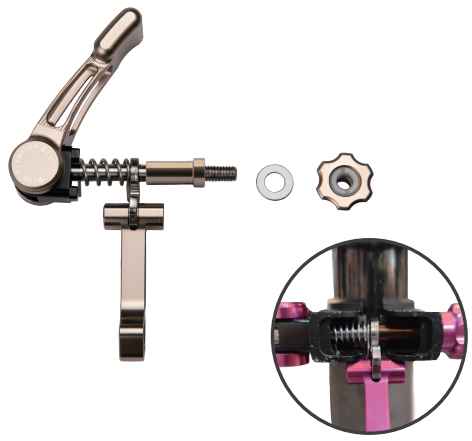

## Installation Steps

1



Uninstall the original seatpost clamp.

2

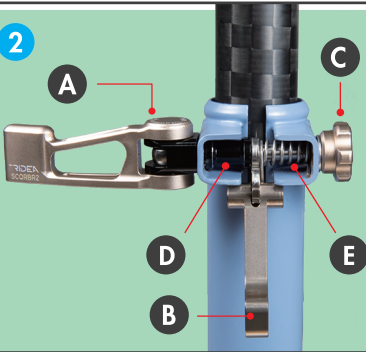

Pass the axis of (A) through the left-side eyelet of the clamp socket. Insert (D) into the axis, followed by (B) and (E). Insert the axis into the socket and pass the axis tip through the right-side eyelet.

**Note:** use the images as a reference for the orientation of the parts. Make sure that the "L" tip of (E) is behind (towards the front of the bike) of (B) and that the straight tip points towards the back of the bike.

3

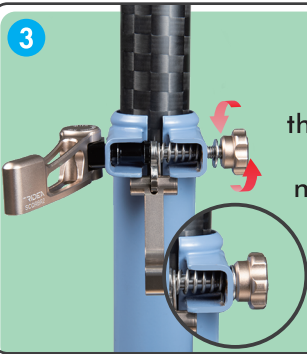

Put the washer in the axis and thread the nut into the axis (clockwise thread).

4

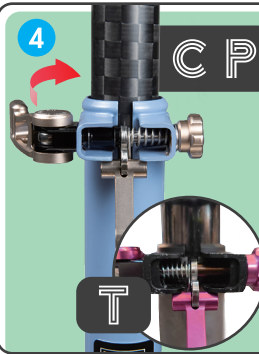

With the QR in the open position, tighten the nut manually until a position where the QR lever leaves you a slight pressure mark in the palm of your hand after closing it.

5



Secure the rear wheel and make sure that the frame release holds it in position. You can lift the bike and shake it, or drop it to the ground, to test that the bike is safe to ride. Release the rear wheel and secure it several times before riding for the first time.